

GUARANTEE & LIABILITY

Your Perrin & Rowe product has been manufactured to exacting standards. However, in the unlikely event that you should experience any defect, the following guarantees will apply:

Your Perrin & Rowe product is guaranteed against any mechanical defect within five years of the date of purchase. Should a fault occur; a free replacement part will be issued.

The surface finish of Perrin & Rowe products are guaranteed for one year from the date of purchase. This is provided our care and maintenance instructions have been followed and that no scouring or aggressive cleaning agents have been used.

This does not affect your statutory rights.
For full terms and conditions please contact your local distributor.

Replacement Pump Heads - Please specify colour

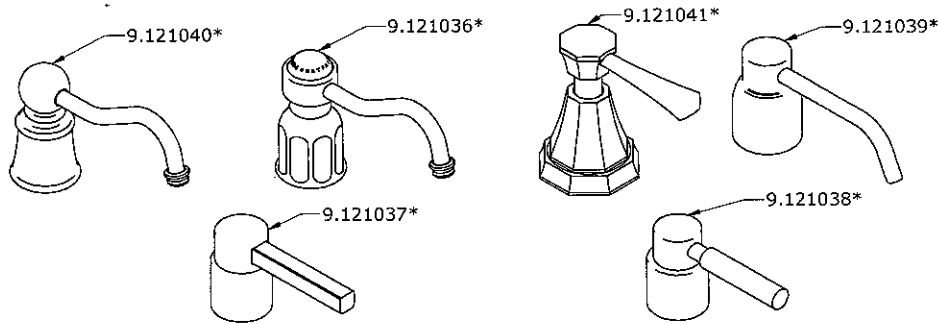

Replacement Pump Assembly

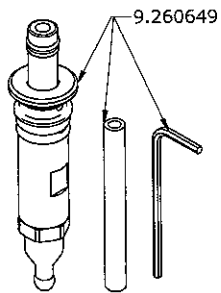

Pump Replacement Method

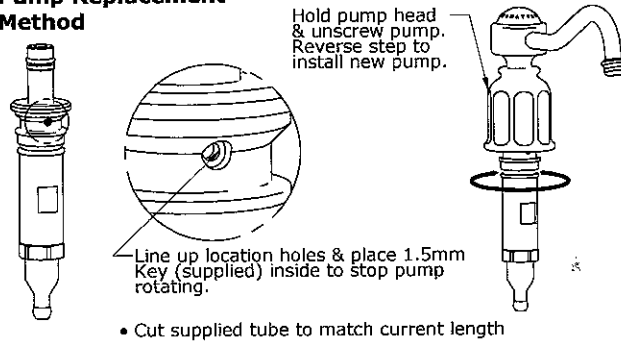

Should you require any advice, or a quick solution to a problem with this product please contact in the first instance the supplier/showroom from which it was purchased.

Perrin and Rowe products are manufactured in the UK, using the latest technology and built to the highest quality standards.

We would like to thank you for purchasing a Perrin and Rowe product and take this opportunity to invite you to look at other luxury products by us. Please contact us to receive our latest catalogue.



The Soap Dispenser Collection

Installation & User Guide

The Soap Dispenser Collection

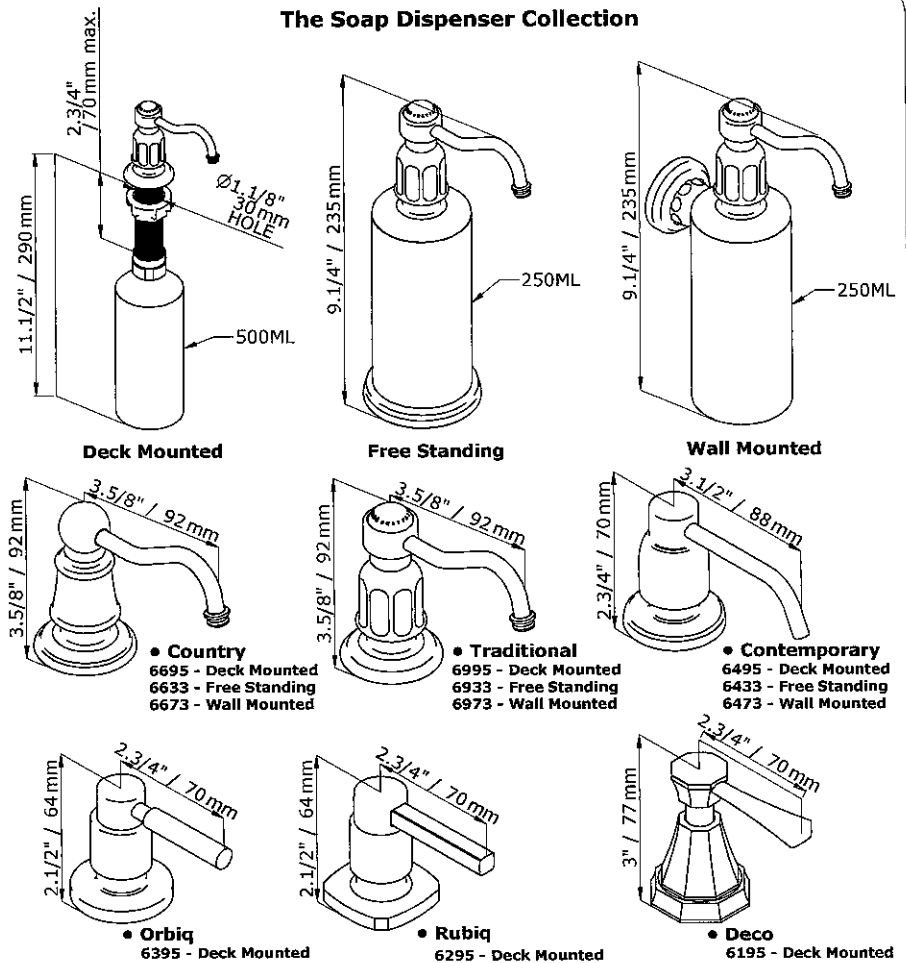

Congratulations on the purchase of your Perrin & Rowe Product. Correctly installed and with sensible care, this product will give you many years of trouble free service.

IMPORTANT INFORMATION

When drilling into tiled walls, be careful to avoid the drill slipping and damaging the glazed surface.

Before you proceed... We recommend you engage the services of a registered plumber to install this product.

In addition to the guide below it is essential that the written information overleaf is carefully read and understood.

For ease of possible future servicing, we also recommend the soap pump assembly be flushed with warm water every 6 to 7 months pumping warm water through it, preventing any future blockage.

Deck Mounted

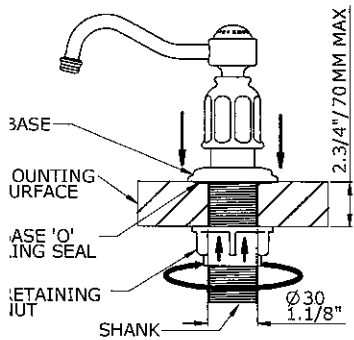

The diameter of the hole should be $\varnothing 30\text{mm}/1.1/8"$. The maximum thickness of the surface must not exceed $70\text{mm}/2.3/4"$

Before inserting the Dispenser Top & Shank ensure the Base part is screwed onto the Shank section and surface area is clean and dry.

Please note: The Base 'O' Ring Seal is an essential item and must be fitted as indicated in diagram.

Once the Shank has been placed through the hole ensure the base seal is immediately above the mounting surface.

Screw the Retaining Nut onto the Shank beneath the mounting surface - hand tight is sufficient.

Wall Mounted

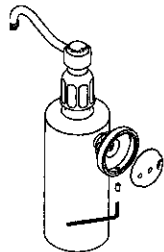

When positioning the soap dispenser, note that the clamping screw is positioned at the base of the rosette. Release wallplate by unscrewing clamping screw from the base of the rosette. (See hole template for correct screw hole positions)

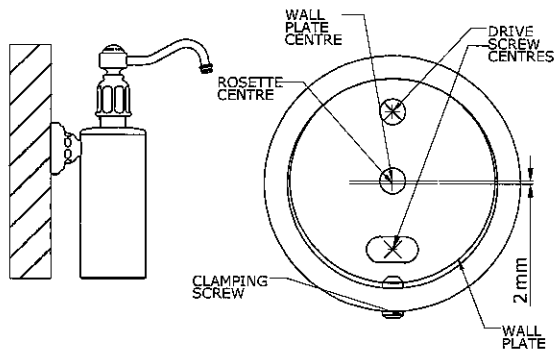

Note that the centre line of the wallplate for these fittings is 2mm above the centre line of the accessory rosette.

Before drilling holes, check centre positions using the accessory as a guide, clamping screw holes should line up with marked positions.

Use No. 6 masonry drill for the supplied wall plugs. Only use supplied wall plugs where suitable.

4. Service/Refill

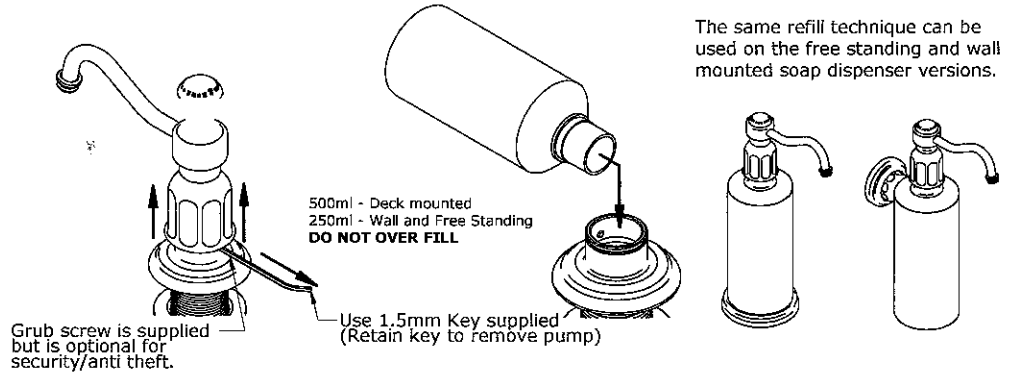

The same refill technique can be used on the free standing and wall mounted soap dispenser versions.

*** IMPORTANT *** DO NOT OVER TIGHTEN GRUB SCREW

Tighten until screw is flush with dispenser head.

If pump feels stiff check that the screw has not been over tightened.

- Remove security screw if fitted.
- Pull dispenser pump head upwards and refill the container.
- Push pump head back into position when filled.
- Re-fit security screw if required.***

5. OPERATION

When used for the first time it may be necessary for you to prime the pump with several downward movements.

The soap is dispensed by a single full movement downwards.

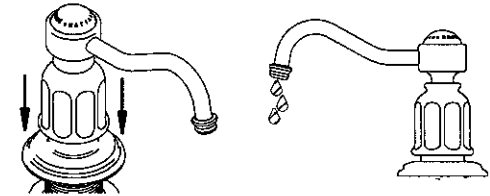

BEFORE USE

- If further building work is to be carried out in the vicinity, cover the accessory to avoid damaging the finish.

CARE & MAINTENANCE

Wipe down after use to avoid water spotting and mineral build up. Due to metals in this product, if left for long periods some soaps may discolour.

Occasional cleaning with warm soapy water, followed by a polish with a soft cloth is all that is required to keep the plated finish in good condition.

Do not use proprietary abrasive liquids, powders, or pads to clean the dispenser. Do not use any products with ammonia bleach or limescale remover. You will damage the plated finish and void your guarantee.